



# Desktop 3D™

The Desktop 3D is a compact haptic device with 3D active translations and 6 degrees-of-freedom measurements. Its workspace and small footprint address it to an individual use, in front of a desktop screen, a head-mounted display (HMD) or inside a simulator.

# Research

# Medical teleoperation

# Virtual Reality

# Medical training & simulation



## 3 ACTIVE TRANSLATIONS + 3 PASSIVE ROTATIONS = 6 MEASUREMENTS

- ✓ Passive weight balancing
- ✓ Ethernet/UDP communication system
- ✓ Removable end-effector, on request.
- ✓ Software interface:
  - ✓ Drivers (binary and/or source code) available for: Python™ for IPSI™, ROS™, ROS2™, CHAI3D™, ODE™, Matlab Simulink™, LabVIEW™
  - ✓ Dedicated plug-ins for: 3DExperience™, Catia™ & Delmia™ V5, Solidworks™
  - ✓ Solutions for Unity, Unreal, and other real-time interactive simulation platforms by our Partners : LS Group, Tree-C, TOIA Ltd, ...

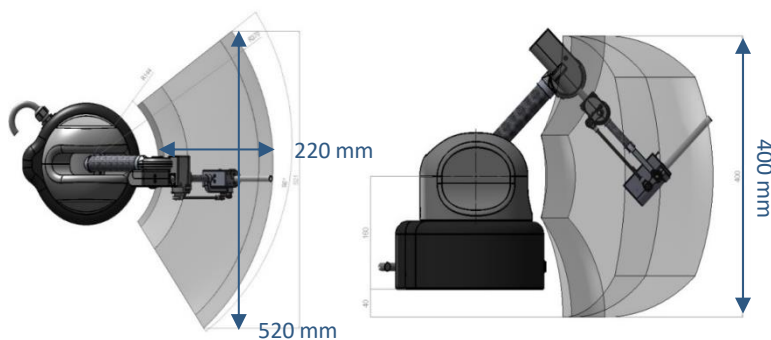

## MODULARITY

On the end-effector, a user button close mounted on the device, permit for instance to be used a shift feature to extend the workspace.

The end effector orientation can be modified.

The device can also be configured in up-side-down position.

A small independent user buttons box, connected to the control unit, provides three user push-buttons, and one finger detection surface that can deactivate the force feedback when released.



User buttons status are provided to the software interface.

We are available to discuss with you any customized needs you have.

## TECHNICAL

Translation workspace	520 x 220 x 400 mm
Rotation Workspace	260° x 105° x 360°
Payload (center of the workspace):	10 N (peak)/ 3 N (continuous)
Position resolution	0.023 mm
Rotation resolution	0.35 °
Device weight	3.6 kg

## ELECTRICAL

Power supply	100-240 VAC 50/60Hz single phase
Consumption	Less than 200W

## SOFTWARE

Maximum translation stiffness	1000 N/m
Update Rate	1000 Hz

*Information in this document is subject to change without notice.*

**HAPTION S.A.S.**

8 ZA Route de Laval – 53210 SOULGE SUR OUETTE – France

Tel. +33(0)2 43 64 51 20

Email : [contact@haption.com](mailto:contact@haption.com) <https://www.haption.com>

