

# VIRTUOSE 3D™ HIGH FORCE

The Virtuose 3D HF is a 6 degrees-of-freedom haptic device with active translations, specifically designed to interact in Virtual Reality environments. Thanks to its large workspace and high forces, it enables a scale one interaction with digital mock-up from the CAD.

- # Virtual Reality
- # Industrial teleoperation
- # Medical Teleoperation
- # Medical training & simulation



### 3 ACTIVE TRANSLATIONS – 3 PASSIVE ROTATIONS

- ✓ Passive weight balancing
- ✓ Ethernet/UDP communication system
- ✓ Removable handle, equipped with programmable buttons and a proximity sensor connected to a dead-man function
- ✓ Software interface:
  - ✓ Dedicated plug-ins for: 3DEXperience™, Catia™ & Delmia™ V5, Solidworks™
  - ✓ Drivers (binary and/or source code) available for: Python™, ROS™, CHAI3D™, ODE™, Matlab Simulink™
  - ✓ By Partner: Unity3D™

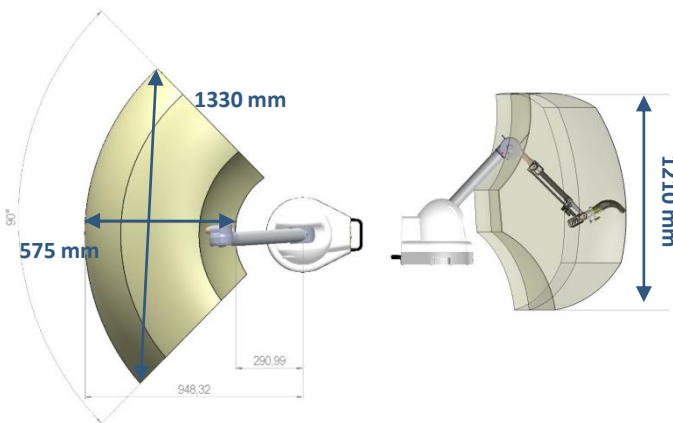

### MODULARITY

The user takes hold of the haptic device using a gripper or handle placed at the tip (called "end-effector"). The end-effector is easy to remove and replace, so that a frequent change of tool is possible, in order to customize the application and reinforce the sensation of immersion. The gripping tool is equipped with three push-buttons. One of the push-buttons is dedicated to the offset function, while the state of the other buttons can be accessed using the VIRTUOSE API.



### TECHNICAL

Translation workspace	1330 x 575 x 1020 mm
Rotation Workspace	330° x 120° x 270°
Payload (center of the workspace):	70 N (peak)/ 35 N (continuous)
Position resolution	0.016 mm
Rotation resolution	0.35 °
Device Weight	12 kg

### ELECTRICAL

Power supply	100-240 VAC 50/60Hz single phase
Consumption	Average consumption 200W Max consumption: 540W

### SOFTWARE

Maximum translation stiffness	2000 N/m
Update Rate	1000 Hz

The Virtuose 6D, Virtuose 6D TAO and Virtuose 3D are also available upside-down. We are available to discuss with you any specific request for integration.